

EDL301T

Ethernet Optic OptoLock® Transceiver



Data Sheet



DESCRIPTION

Firecomms Ethernet transceiver combines both transmitter and receiver fiber optic components in a small form factor housing. OptoLock® allows bare fiber termination of standard jacketed Plastic Optic Fiber (POF) with a simple insert and lock system. It is an ideal solution for Fast Ethernet telecoms-installed IPTV and self-installed home networking. The EDL301T-xxx, delivers bandwidth of 100 Mbps over POF in a point-to-point link. It has a very simple interface to any Ethernet PHY IC supporting IEEE 802.3 100Base-FX.

The OptoLock® design enables the fiber to be cut to length on-site with minimum of waste, and terminated quickly and reliably without the need for expensive equipment or specially trained staff (no splicing required).

The transmitter is a high speed RCLED (Resonant Cavity LED) driven by a CMOS IC. The receiver combines a photodiode, transimpedance amplifier and limiting amplifier, providing a digital output on an LVPECL data bus compatible with all Ethernet PHY ICs. OptoLock® is protected by U.S. patents 7,597,485 and 7,905,665, Chinese patents 101501545 A and 102135650 B and other international patents.

AVAILABLE OPTIONS

Part Number	Description
EDL301T-220	OptoLock® Ethernet Transceiver for 2.2mm POF, Black
EDL301T-229	OptoLock® Ethernet Transceiver for 2.2mm POF, White
EDL301T-150	OptoLock® Ethernet Transceiver for 1.5mm POF, Black
EDL301T-159	OptoLock Ethernet Transceiver for 1.5mm POF, White



FEATURES

- Simple low-cost termination solution for bare POF
- Suitable for standard 1.5 mm or 2.2 mm POF
- LVPECL output data bus (800-1400) mV
- Visible red light from eye-safe RCLED
- Includes CMOS LED driver (TX)
- High-sensitivity CMOS receiver and silicon Photodiode (PD)
- Integrated optics to efficiently couple light to and from 1mm fiber core with 0.5 or 0.3 NA
- Compatible with IEEE 802.3u Fast Ethernet data communications standard
- Seamless digital to light/light to digital conversion
- RoHS compliant

APPLICATIONS

Application	Industrial Networking
Standard	IEEE 802.3 (100Base-FX)
Distance	50 meters Step Index POF [1]
Speed	125 Mbps

Note: 1. Depending on the installation conditions

SPECIFICATIONS

Table 3
TRANSCEIVER PIN DESCRIPTION

Pin	Name	Symbol
Transmitter		
1	EMI Shield ^[1]	GND
2	Signal Input (Negative)	TD-
3	Signal Input (Positive)	TD+
4	Ground Pin ^[1]	GND
5	DC Power Input Pin 3.3 V	Vcc
6	Ground Pin ^[1]	GND
Receiver		
7	DC Power Input Pin 3.3 V	Vcc
8	Ground Pin ^[1]	GND
9	Signal Detect Output	SD
10	Data Output (Negative)	RD-
11	Data Output (Positive)	RD+
12	EMI Shield ^[1]	GND

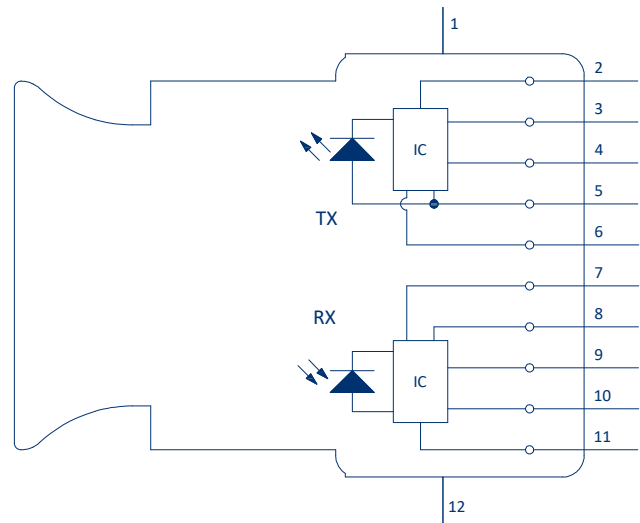

FIGURE 1
Transceiver pin-out, top view

1. NB: EMI Shield ground pins must be connected to the signal ground plane on the PCB. This is important to prevent cross-talk between TX and RX and also to shield the FOT's from external EMI/EMC and ESD

Table 4
REGULATORY COMPLIANCE

Parameter	Symbol	Standard	Level
Storage Compliance	MSL	J-STD-020E	2a (4-week floor life)
Restriction of Hazardous Substances Directive	RoHS	Directive 2011/65/EU	Certified compliant
Eye Safety		IEC 60825-1	LED Class 1

RECOMMENDED APPLICATION CIRCUIT

The generalized recommended application circuit is shown in Figure 2. Each PHY IC manufacturer will recommend a termination configuration for their design; please refer to the relevant product data sheets. Some examples from the most popular PHYs are provided in Firecomms' EDL301T Application Note. It is important that the data lines are treated as controlled impedance, matched differential pairs, and that the crystal used in conjunction with the PHY is of a suitably high tolerance.

Signal Detect is an open-collector CMOS output from the receiver (RX). It is low (≤ 0.6 V) when there is no optical data or optical data below the lower optical power sensitivity level. It is high (≈ 3.3 V) when there is optical data present with a power level above the minimum sensitivity level.

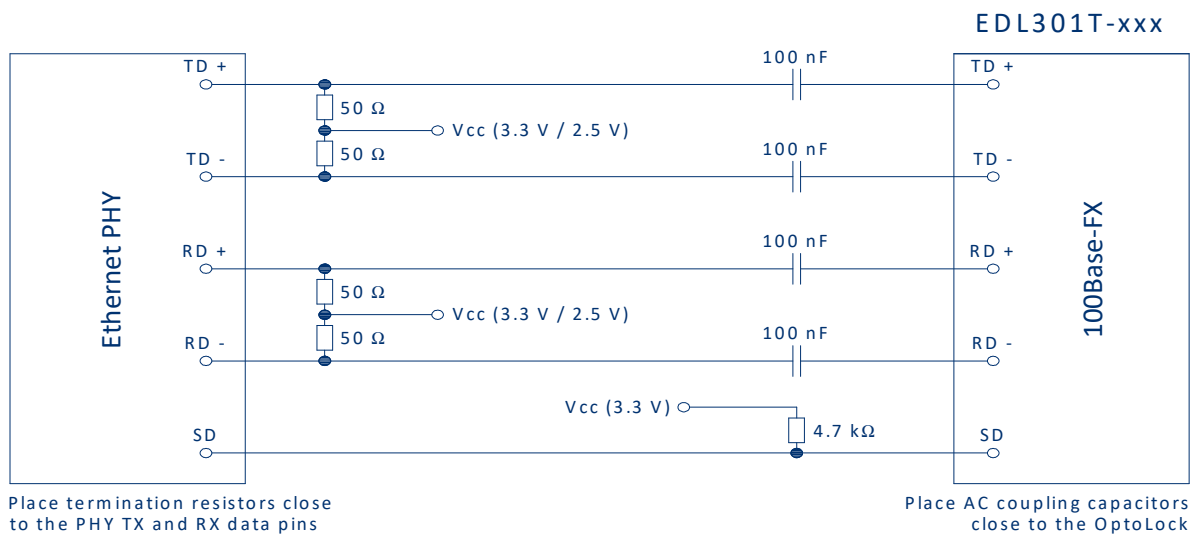

FIGURE 2
Recommended application circuit layout for an AC coupled EDL301T-xxx.

ELECTRONIC BLOCK DIAGRAM

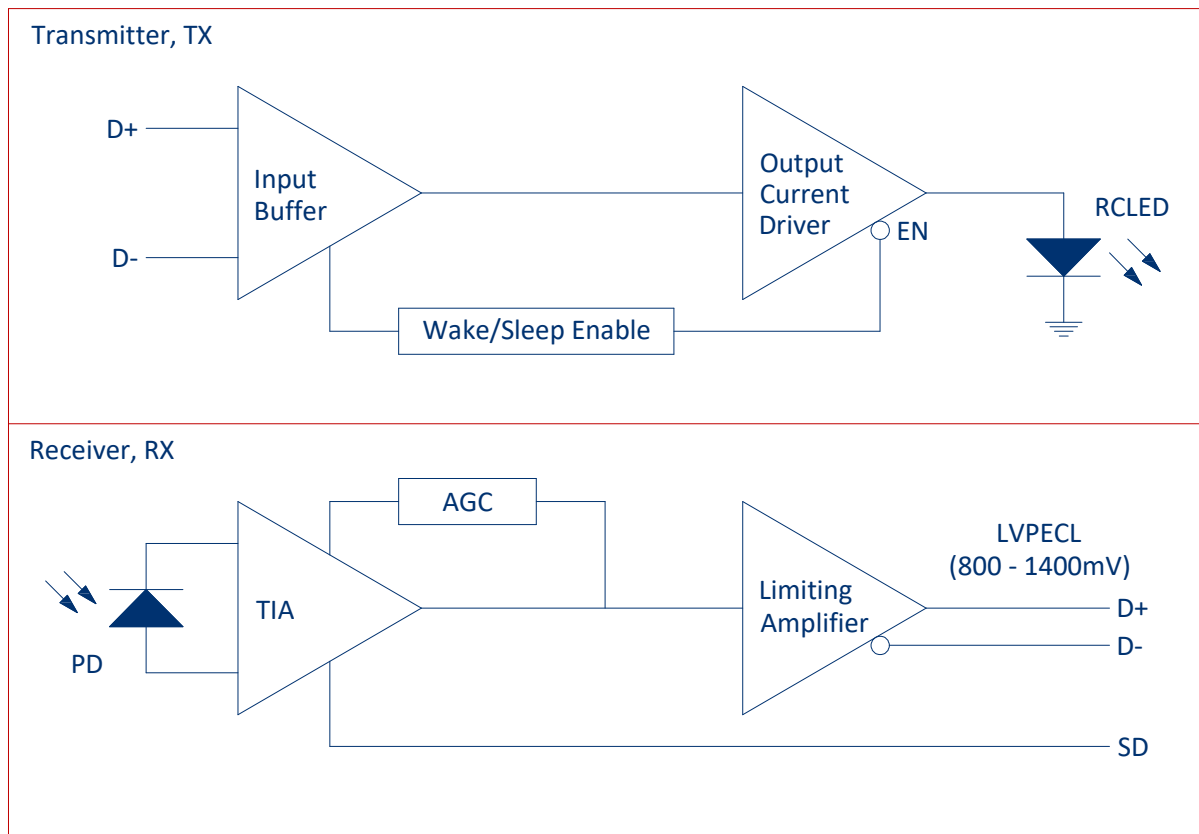

FIGURE 3
Electronic block diagram of the EDL301T-xxx.

SPECIFICATIONS

Table 5
ABSOLUTE MAXIMUM RATINGS

These are the absolute maximum ratings at or beyond which the component can be expected to be damaged

Notes:

1. 260 °C for 10 seconds, one time only, at least 2.2 mm away from lead root

Parameter	Symbol	Minimum	Maximum	Unit
Storage Temperature	T _{stg}	-20	+85	°C
Operating Temperature	T _{op}	-20	+70	°C
Soldering Temperature ^[1]			+260	°C
Supply Voltage	V _{CC}	-0.5	+4.5	V
Receiver Optical Power Overload	P _{OL}		0	dBm

SPECIFICATIONS

Table 6
TRANSMITTER ELECTRICAL AND OPTICAL CHARACTERISTICS

Parameter	Symbol	Min	Typical	Max	Unit	Test Condition
Supply Voltage	V_{CC}	3.00	3.30	3.60	V	
Current Consumption	I_{CC}	30.0	37.0	52.0	mA	
Data Rate		10	100	125	Mbps	
Input Capacitance	C_{in}			5.00	pF	
Input Resistance	R_{in}		5.00		k Ω	
Input Common-Mode Voltage Range	V_{IB}	GND+0.8		V_{CC} -0.8	V	
Differential Input Voltage Swing	V_{ID}	100		1200	mV	
Optical Power OFF Delay	T_{PD}	0.02		20.00	μ s	
Optical Power ON Delay	T_{PU}			5.00	μ s	
Peak Wavelength	λ_{peak}	640	660	670	nm	
Spectral Bandwidth (FWHM)	$\Delta\lambda$	18	24	27	nm	
Average Output Power	P_{50}	-8.5	-5.5	-1.5	dBm	
Optical Rise Time (20 % - 80 %)	T_R	0.50	1.30	2.50	ns	
Optical Fall Time (80 % - 20 %)	T_F	0.40	0.50	0.60	ns	
Optical Modulation Amplitude	OMA	160	590	1250	μ W	
Open Eye Width	T_{eye}	6.5	7.4	7.9	ns	

Table 7
RECEIVER ELECTRICAL AND OPTICAL CHARACTERISTICS

Notes:

1. All tests were performed using an OptoLock connector for 2.2mm jacket coupled to 1mm core 0.5NA POF.
2. Test data was obtained at the upper data rate limit of 100 Mbps using a PRBS7 (encoded, 125MBd) test pattern.
3. Test data was validated at 125 Mbps over the temperature range -20 °C to +70 °C and over the supply voltage range 2.97 V to 3.63V.

Parameter	Symbol	Min	Typical	Max	Unit	Test Condition
Supply Voltage	V _{CC}	3.0	3.3	3.6	V	
Current Consumption	I _{CC}	35	43	50	mA	
Data Rate		10	100	125	Mbps	[3]
Output Differential Impedance	R _{DIFF}		100		Ω	
Output Common-Mode Voltage	V _{OB}		1.2		V	
Output Differential Voltage Swing	V _{OD}	800	1150	1400	mV	
Optical Rise Time (10% - 90%)	T _R	2	1.6	3	ns	10 % - 90 %
Optical Fall Time (90% - 10%)	T _F	2	1.6	3	ns	90 % - 10 %
Average Input Sensitivity	P _{in}			-24	dBm	
Optical Overload				0	dBm	
Signal Detect Assert/De-assert Time	T _{SD}	0.1	0.25	0.6	μs	
Signal Detect Optical Assert Level	p _{SD-AS}	-32.0	-27.5	-24.0	dBm	
Signal Detect Optical De-assert Level	P _{SD-DAS}	-32.0	-28.5	-25.0	dBm	
Signal Detect Voltage High (V _{OH} -V _{CC})	V _{SDH}	2.4	3.0	3.6	V	
Signal Detect Voltage Low (V _{OL} -V _{CC})	V _{SDL}	0.0	0.05	0.10	V	
Open Eye Width	EW	6.5	7.4	7.9	ns	

MECHANICAL DATA

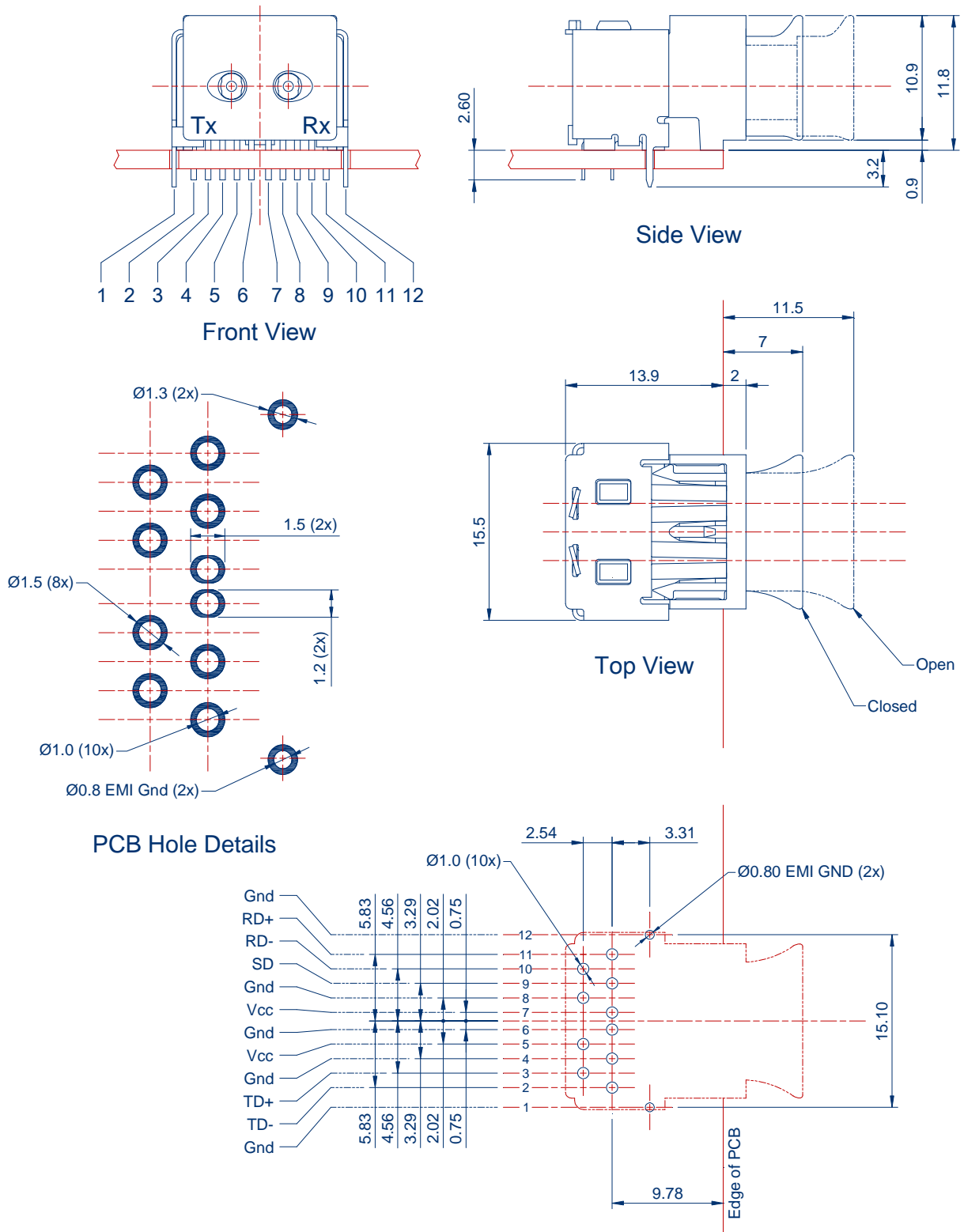

FIGURE 4

Mechanical dimensions of the product, and PCB footprint, which is a top view

General dimensional tolerance is ± 0.2 mm

NOTE: For PCB layout extra care is required with pin 6 and pin 7. On the PCB top and bottom metal they require a non-circular pad. The VIA's are standard plated circular through holes, however, the VIA top and bottom solder pad areas are non-circular 1.2 mm wide and 1.5 mm long oval shapes.

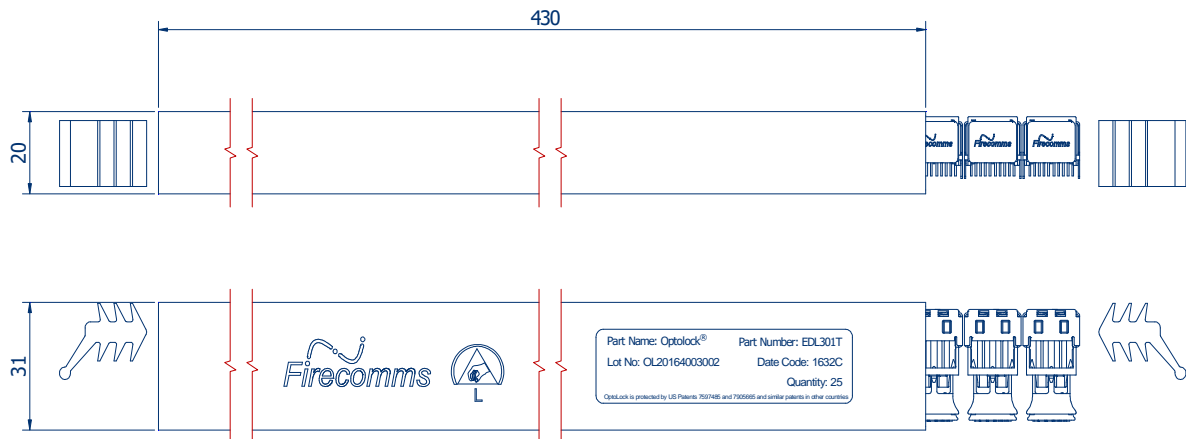

FIGURE 5
Packing tube for Firecomms EDL301T OptoLock® Transceivers

PART HANDLING

These transceivers are tested for handling in static-controlled assembly processes (HBM). Cleaning, degreasing and post solder washing should be carried out using standard solutions compatible with both plastics and the environment. For example, recommended solutions for degreasing are alcohols (methyl, isopropyl and isobutyl). Acetone, ethyl acetate, phenol or similar solution based products are not permitted.

In the soldering process, non-halogenated water soluble fluxes are recommended. These components are not suitable for use in reflow solder processes (infrared/vapor-phase reflow). The dust plug should remain in place during soldering, washing and drying processes to avoid contamination of the active optical area of each connector.

The Moisture Sensitivity Level (MSL) classification of this device is 2a according to JEDEC J-STD-020E. The shelf life of an unopened MBB (Moisture Barrier Bag) is 24 months at < 40 °C and < 90 % R.H. Once the Moisture Barrier Bag is opened the devices can be either

- a) Stored in normal factory conditions < 30 °C and < 60 % R.H. for a maximum of 672 hours (4 Weeks) prior to soldering.
- b) Stored at < 10 % R.H. (Dry Cabinet).

PACKING INFORMATION

Components are packed in PVC anti-static tubes in moisture barrier bags. Bags should be opened only in static-controlled locations, and standard procedures should be followed for handling moisture sensitive components

Components per Tube	25
Tube Length	430 mm
Tube Height	20 mm
Tube Depth	31 mm
Tubes per Moisture Barrier Bag	10
Moisture Barrier Bags per Inner Carton	1
Inner Carton Length	588 mm
Inner Carton Width	147 mm
Inner Carton Height	84 mm
Weight per Inner Carton, Complete	1.80 kg
Components per Inner Carton	250
Inner Cartons per Outer Carton	4
Outer Carton Length	600 mm
Outer Carton Width	310 mm
Outer Carton Height	195 mm
Weight per Outer Carton, Complete	7.53 kg
Components per Outer Carton	1,000

For the most recent revision or further information please visit www.firecomms.com or contact the company directly at the following address, Firecomms Ltd, 2200 Airport Business Park, Cork, IRELAND. Copyright© 2004-2017 Firecomms. All rights reserved. Firecomms refers to Firecomms Limited and/or its subsidiaries. Firecomms assumes no responsibility for inaccuracies or omissions in the information contained in this document. Specifications are subject to change without notice. No patent rights are granted to any of the circuits described herein.